



DSL MH2 - 12V

nach EN13155 / max. 1000 kg Tragkraft

- Bis 1000 kg Tragkraft
- inkl. Verbreiterung



Technische Daten:

- 12 V Batteriebetrieb
- Zweikreissauganlage
- Netzbetrieb
- Inkl. Kabelfernbedienung
- Motorisch Drehen 360°
- Hydraulisch Kippen 90°
- Eigengewicht 250 kg
- Warneinrichtung
- Spannungsanzeige
- Vakuumtank



Robert Kappel GmbH

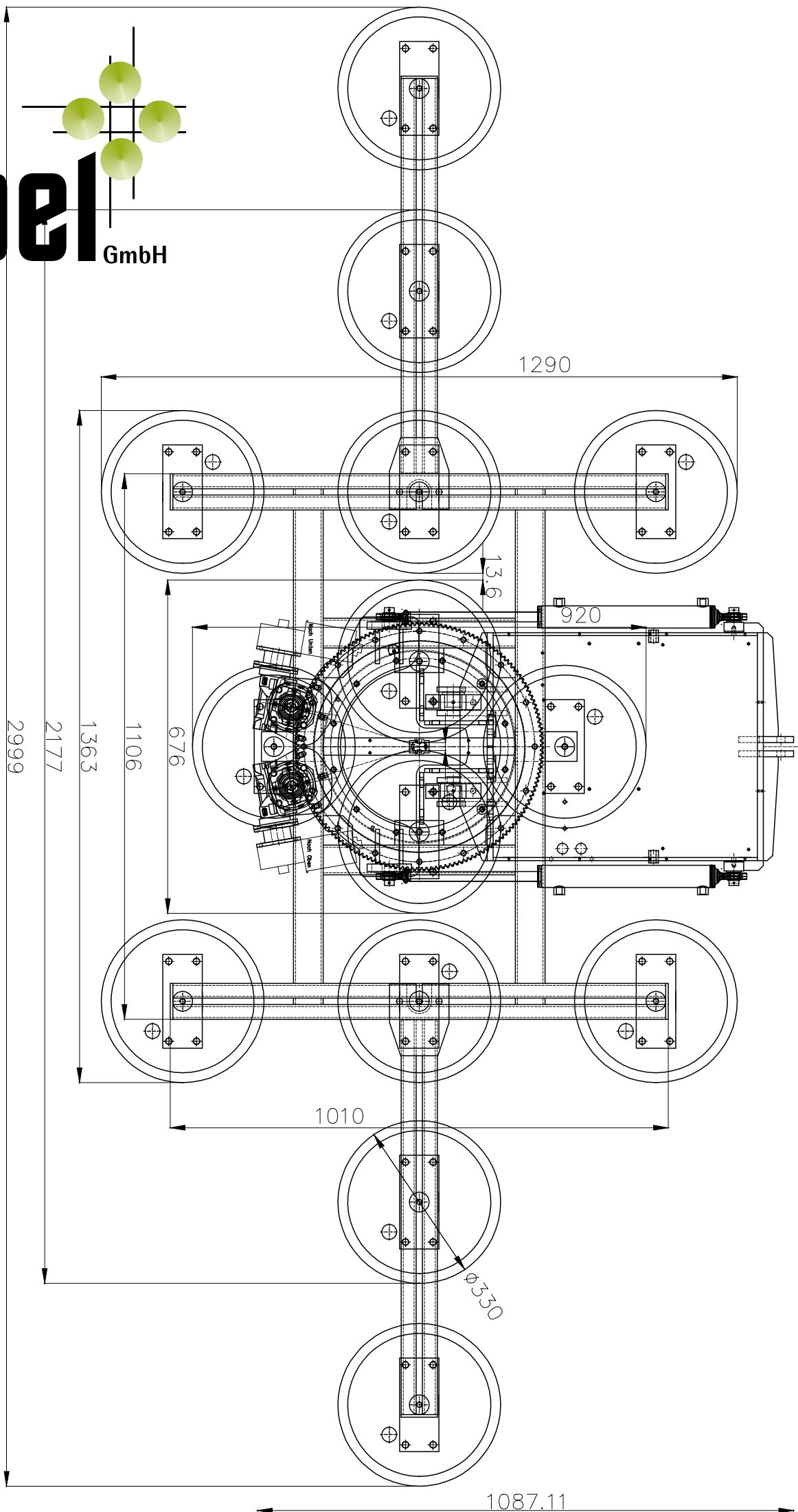
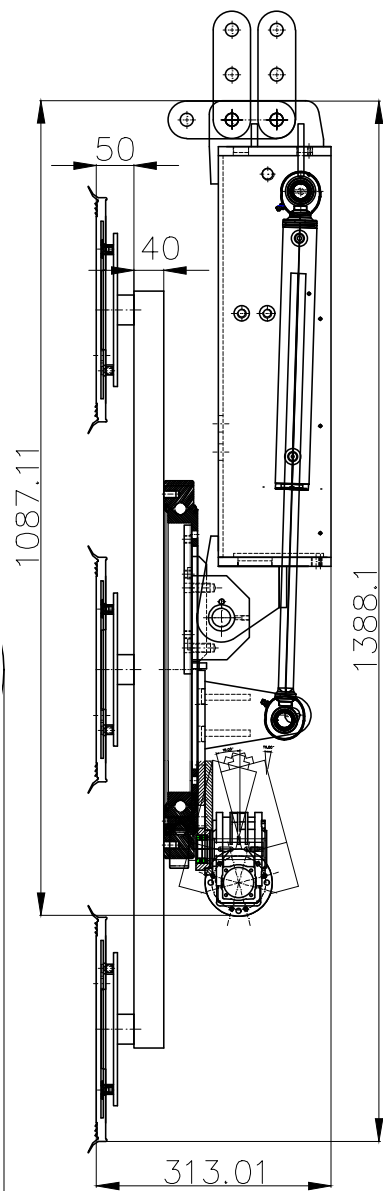

29999
21777
13663
1106

1087.11