



- Bis 2000 kg Tragkraft
- inkl. Verbreiterung



Technische Daten:

- 12 V Batteriebetrieb
- Zweikreissauganlage
- Netzbetrieb
- Inkl. Kabelfernbedienung
- Motorisch Drehen 360°
- Hydraulisch Kippen 90°
- Eigengewicht 420 kg
- Warneinrichtung
- Spannungsanzeige
- Vakuumtank



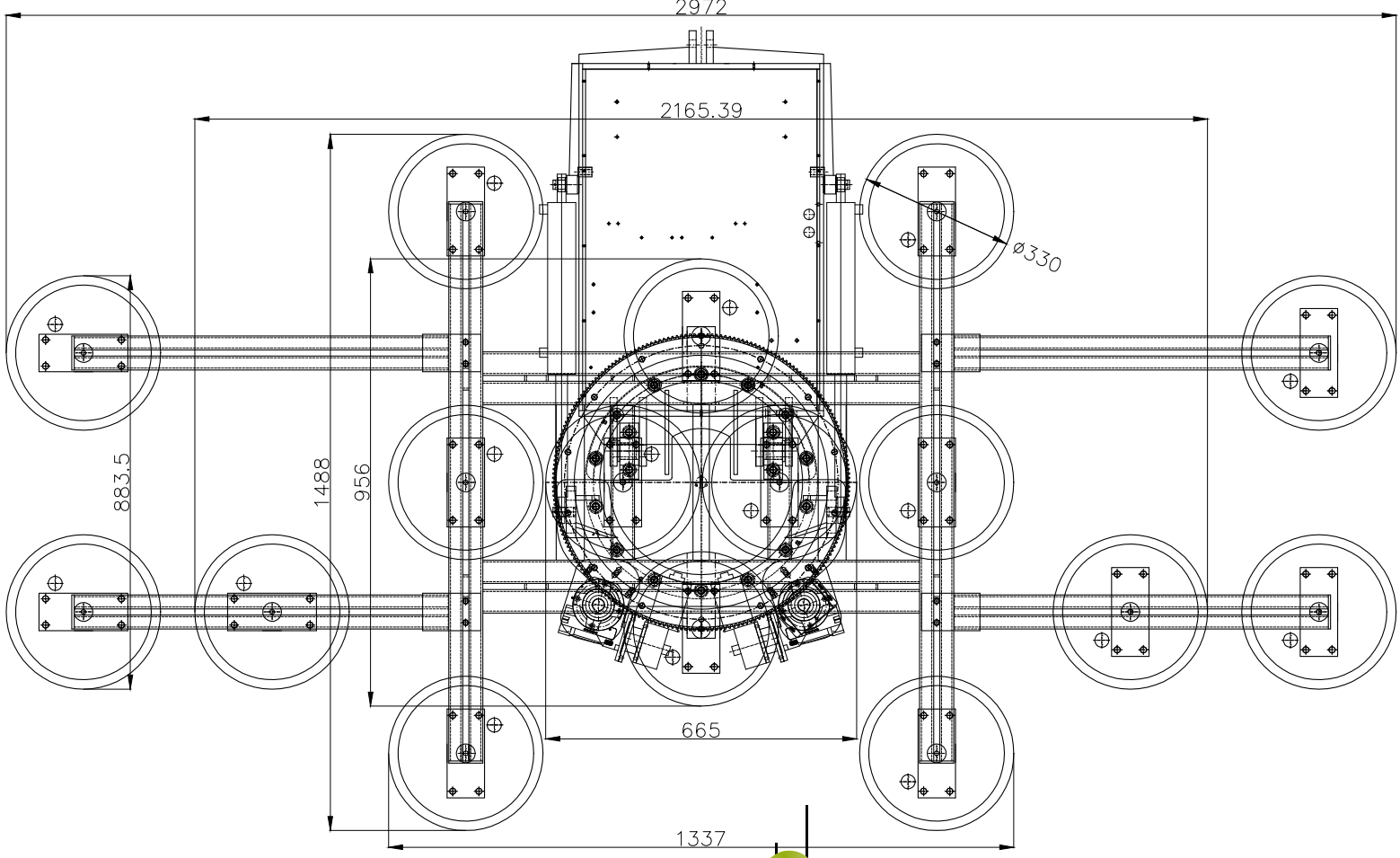

Robert
Kappel
 GmbH

